

# 135 Draper Platform



## TECHNICAL MANUAL 135 Draper Platform

TM1280 (01JUL82) English

**Ottumwa Works**  
**TM1280 (01JUL82)**

LITHO IN U.S.A.  
ENGLISH

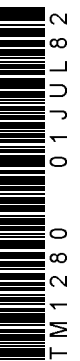



# 135 DRAPER PLATFORM TECHNICAL MANUAL TM-1280 (JUL-82)

## CONTENTS

### SECTION 10 - GENERAL

- Group 05 - Safety
- Group 10 - Specifications and Torques
- Group 15 - Description
- Group 20 - Lubrication

### SECTION 20 - POWER TRAIN

- Group 05 - Reel
- Group 10 - PTO Hookup
- Group 15 - Gear Case
- Group 20 - Right-Hand and Left-Hand  
Cross Shaft
- Group 25 - Canvas
- Group 30 - 35 and 65 Conditioner

### SECTION 30 - HYDRAULIC SYSTEM

- Group 05 - Diagnosis and Tests
- Group 10 - Control Valve
- Group 15 - Reel Drive Motor
- Group 20 - Reel Lift Cylinders
- Group 25 - Reel Drive Pump
- Group 30 - Reservoir

### SECTION 40 - CUTTING COMPONENTS

- Group 05 - Knife Drive Case
- Group 10 - Cutterbars
- Group 15 - Knives

### SECTION 50 - SPECIAL TOOLS

- Group 05 - Fabricated Tools
- Group 10 - Special Tools

COPYRIGHT© 1982  
DEERE & COMPANY  
Moline, Illinois  
All rights reserved  
A JOHN DEERE ILLUSTRATION

*All information, illustrations and specifications contained in this technical manual are based on the latest information available at the time of publication. The right is reserved to make changes at any time without notice.*

0A9: E05:0000 ZA 200882

## INTRODUCTION

This technical manual is part of a twin concept of service:

### **FOS Manuals—for reference**

### **Technical Manuals—for actual service**

The two kinds of manuals work as a team to give you both the general background and technical details of shop service.

*Fundamentals of Service (FOS) Manuals* cover basic theory of operation, *fundamentals* of trouble shooting, *general* maintenance, and *basic* types of failures and their causes. FOS Manuals are for training new people and for reference by experienced technicians.

*Technical Manuals* are *concise* service guides for a *specific* machine. Technical Manuals are on-the-job guides containing only the vital information needed by an experienced technician.

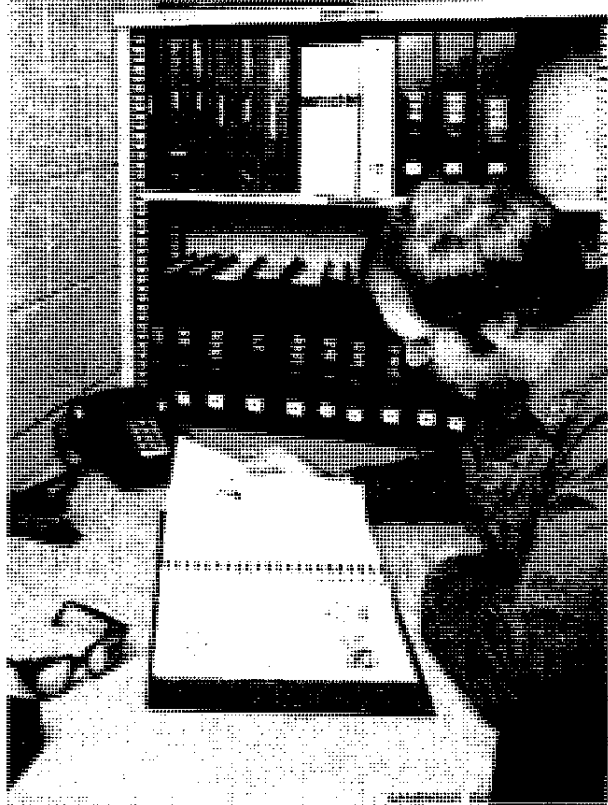

## FEATURES OF THIS TECHNICAL MANUAL

- John Deere ILLUSTRATION format emphasizing more detailed pictures and fewer words.
- Instructions and illustrations grouped together in easy-to-use modules.
- Removal and installation groups preceding some repair groups. These groups show how to remove and install components from the machine rather than from major components. They also show how to acquire access to major components of a machine.
- *Exploded views showing parts relationship.*

This technical manual was planned and written for you—an experienced technician. Keep it in a permanent binder in the shop where it is handy. Refer to it whenever in doubt about correct service procedures or specifications.

Using the technical manual as a guide will reduce error and costly delay. It will also assure you the best in finished service work.

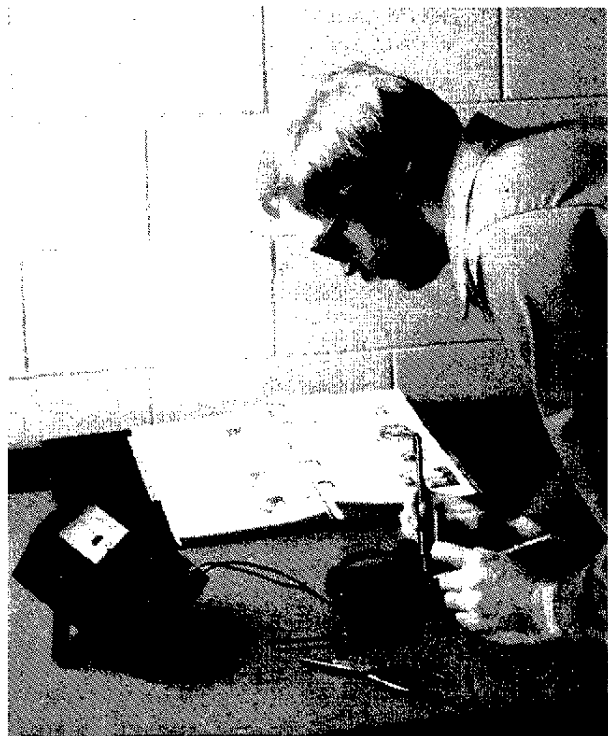

DA9:RW5560 E05:0000 ZC 160882

**Thanks very much for your reading,  
Want to get more information,  
Please click here, Then get the complete  
manual**

**JustClickHere** 

**NOTE:**

**If there is no response to click on the link above,  
please download the PDF document first, and then  
click on it.**

**Have any questions please write to me:  
[admin@servicemanualperfect.com](mailto:admin@servicemanualperfect.com)**

# Section 10 GENERAL

## CONTENTS

	Page		Page
Introduction .....	10-02	<b>GROUP 15 - DESCRIPTION</b>	
Features of this Technical Manual .....	10-02	Platform with Mechanical Reel Drive ...	10-15-01
<b>GROUP 05 - SAFETY</b>		<b>GROUP 20 - LUBRICATION</b>	
Safety Messages .....	10-05-01	Lubricate Platform Properly .....	10-20-01
<b>GROUP 10 - SPECIFICATIONS AND TORQUES</b>		Choosing a Grease .....	10-20-01
Platform .....	10-10-01	Knife Drive Case .....	10-20-02
Hay Conditioner:		Gear Case .....	10-20-02
35 Conditioner .....	10-10-02	Use Approved Alternate Lubricants ....	10-20-02
65 Conditioner .....	10-10-02	Store Lubricants Correctly .....	10-20-03
Torque Chart .....	10-10-03	Choosing Hydraulic Oil .....	10-20-03
		Lubrication Services .....	10-20-04

*Contents*

### **SAFETY MESSAGES**



This safety alert symbol and the word **CAUTION** identify important safety messages in this manual and on the platform. When you see this symbol, be alert to the possibility of personal injury and carefully read the message that follows.

0A9; E05:1005 ZE 300682

### **IMPORTANT**

The **IMPORTANT** message identifies potential problems which may cause consequential damage to the platform. Following the recommended procedure will instruct the technician how to avoid the problem.

0A9; E05:1005 ZF 300682

### **NOTES**

The word *NOTE* is followed by a statement that identifies a qualification or exception to a previous statement. A "NOTE" may also identify nice-to-know information pertinent to, but not directly related to the previous statement.

0A9; E05:1005 ZG 140682



## USE ADEQUATE SERVICE FACILITIES

Keep the service area clean and dry. Wet or oily floors are slippery. Wet spots can be dangerous when working with electrical equipment.

Make sure the service area is adequately vented.

Periodically check the shop exhaust system for leakage. Engine exhaust gas is dangerous.

Be sure all electrical outlets and tools are properly grounded.

Use adequate light for the job at hand.

Use lifting equipment and safety stands which have adequate strength for the job being performed.

Wear fairly tight clothing.

Know where the first aid kit and fire extinguishers are located, and know how to use them.

0A9; E05;1005 ZH 140682

## PRACTICE SAFE MAINTENANCE

Before servicing or adjusting the platform or removing material from it always:

1. Disengage all drives.
2. Shut off windrower engine,
3. THEN WAIT until all moving parts have stopped rotating.

Do not leave windrower unattended with platform raised. Always lower it to the ground. When platform is raised for servicing, secure hydraulic stop on each side of the windrower.

Always engage both hydraulic cylinder stops on reel when working on platform with reel raised.

Keep hands, feet and clothing away from moving parts.

Never attempt to clear obstructions off the platform unless the windrower engine is shut off.

Replace any guards and shields removed for servicing.

0A9; E05;1005 ZI 200682

## Safety

Wear safety equipment.

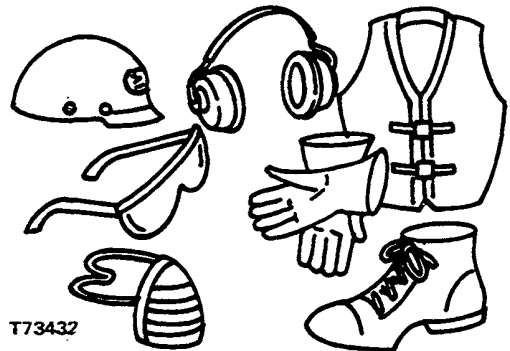

T73432

0A9:T73432 E05:1005 ZJ 150682

### AVOID HIGH-PRESSURE FLUIDS

Escaping fluid under pressure can penetrate the skin, causing serious injury. Relieve pressure before disconnecting hydraulic or other lines. Tighten all connections before applying pressure. Keep hands and body away from pinholes and nozzles which eject fluids under high pressure. Use a piece of cardboard or paper to search for leaks. Do not use your hand.

If ANY fluid is injected into the skin, it must be surgically removed within a few hours by a doctor familiar with this type injury or gangrene may result.

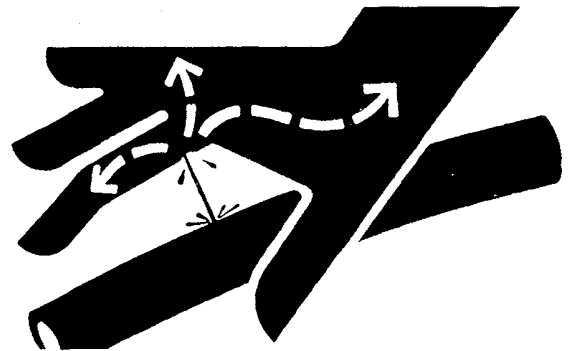

0A9:X9811 E05:1005 ZK 200882

## AVOID FIRE HAZARDS

Be prepared if an accident or fire should occur. Know where the first aid kit and the fire extinguishers are located-know how to use them.

Don't smoke while refueling or handling highly flammable material.

Shut off the engine when refueling.

Use care in refueling if the engine is hot.

Don't use open pans of gasoline or diesel fuel for cleaning parts. Use good commercial, nonflammable solvents.

Provide adequate ventilation when charging batteries.

Don't check battery charge by placing metal objects across the posts.

Don't allow sparks or open flame near batteries.,

Don't smoke near battery.

Never check fuel, battery electrolyte, or coolant levels with an open flame.

Never use an open flame to look for leaks anywhere on the equipment.

Never use an open flame as light anywhere on or around the equipment.

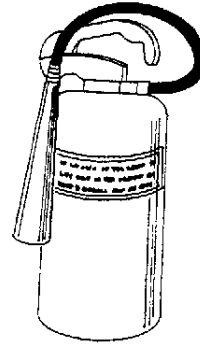

N35540

0A9:N35540 E05:1005 ZL 300682

## PROTECT AGAINST NOISE

Prolonged exposure to loud noise can cause impairment or loss of hearing.

Wear a suitable hearing protective device such as earmuffs (A) or earplugs (B) to protect against objectionable or uncomfortable loud noises.

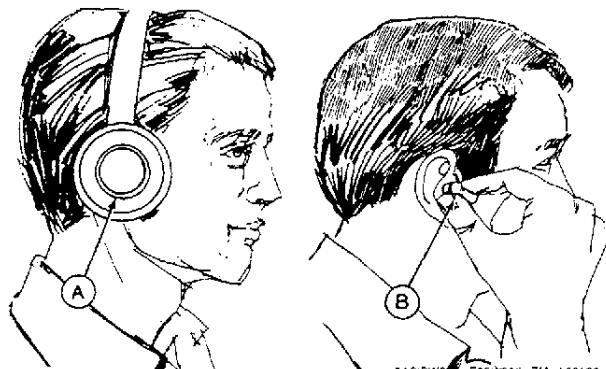

0A9:RW255 E05:1005 ZM 150682

**SPECIFICATIONS AND TORQUES**

**PLATFORM**

**WIDTH**

Platform ..... 3658 mm (12 ft.)

**CUTTERBAR**

Type of Drive ..... Enclosed, running in oil  
 Speed ..... 730 rpm, 1460 strokes per min.  
 Guards ..... Double tine  
 Guard Angle ..... Variable, 6 to 12 degrees  
 Knives ..... Underserrated standard  
 (Overserrated and smooth knives available)

**REEL**

Type ..... Pickup  
 Speed ..... Variable, mechanical 35-66 rpm  
 Variable, hydraulic 5-76 rpm

Adjustments:

Vertical ..... 762 mm (30 in.)  
 Horizontal ..... 305 mm (12 in.)

**CONVEYOR CANVASSES**

Drive ..... V-belt  
 Draper Tension ..... Spring loaded

**SPEED**

Platform ..... 122-152 m/min (400-500 ft/min)

**PLATFORM CUTTING HEIGHT**

Range ..... -102 to 610 mm (-4 to 24 in.)

**ANGLE**

Platform ..... Variable, 17 to 23 degrees

**CANVAS**

Distance Between . Variable, 965-1118-1270 mm  
 (38-44-50 in.)

**HYDRAULIC RESERVOIR** ..... 17.4 L (4.6 gal.)

**WEIGHT (Less Conditioner)** . 810 kg (1800 lbs)

**SERIAL NUMBER** ... Located on the upper rear  
 portion of the frame on  
 the left-hand side.



## TORQUE CHART

### U.S. MEASUREMENT

Bolt Diameter "A"	Bolt Torque in N·m (Lb-Ft)		
	SAE 2	SAE 5	SAE 8
1/4	Not Used	10 (14)	14 (19)
5/16"	Not Used	20 (27)	30 (41)
3/8"	31 (23)	47 (35)	68 (50)
7/16"	47 (35)	75 (55)	108 (80)
1/2"	75 (55)	115 (85)	163 (120)
9/16"	102 (75)	176 (130)	237 (175)
5/8"	142 (105)	231 (170)	325 (240)
3/4"	251 (185)	407 (300)	576 (425)
7/8"	217 (160)	603 (445)	929 (685)
1"	339 (250)	910 (670)	1396 (1030)
1-1/4"	450 (330)	1235 (910)	1979 (1460)

Replace hardware with same strength bolt.

### METRIC MEASUREMENT

Bolt Diameter "A"	Bolt Torque in N·m (Lb-Ft)	
	8.8	10.9
5 mm	6 (5)	9 (7)
6 mm	11 (9)	17 (13)
8 mm	28 (20)	40 (30)
10 mm	55 (40)	80 (59)
12 mm	95 (70)	140 (103)
16 mm	235 (173)	350 (258)
20 mm	475 (350)	675 (498)
24 mm	825 (608)	1170 (863)
30 mm	1630 (1201)	2320 (1712)

*NOTE: Bolts having lock nuts should be torqued to approximately 65% of amounts shown in above chart.*

*Specification and Torques*

**PLATFORM WITH MECHANICAL REEL DRIVE**

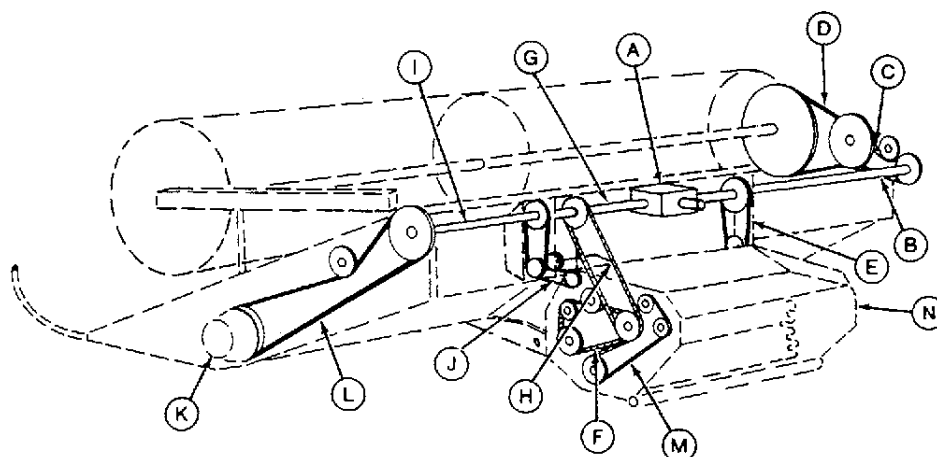

E17039

- |                                 |                                  |                                |                                 |
|---------------------------------|----------------------------------|--------------------------------|---------------------------------|
| <b>A—Platform Gear Case</b>     | <b>E—Right-Hand Drive Belt</b>   | <b>I—Left-Hand Cross shaft</b> | <b>L—Cutterbar Drive Belt</b>   |
| <b>B—Right-Hand Cross Shaft</b> | <b>F—Upper Roll Drive Chain</b>  | <b>J—Left-Hand Drive Belt</b>  | <b>M—Lower Roll Drive Chain</b> |
| <b>C—Reel Drive Chain</b>       | <b>G—Conditioner Cross Shaft</b> | <b>K—Cutterbar Drive Case</b>  | <b>N—Conditioner</b>            |
| <b>D—Reel Drive Belt</b>        | <b>H—Conditioner Drive Chain</b> |                                |                                 |

Power to the draper platform is transmitted from the gear case (A) with right-hand and left-hand cross shafts.

The right-hand cross shaft (B) drives the reel with a roller chain (C) and V-belt combination (D). The roller chain is under tension from an adjustable idler. A spring-loaded idler pulley applies tension to the V-belt. Also, the right-hand draper canvas is driven directly from the cross shaft (B) through a V-belt drive (E).

The hay conditioner rolls are driven by individual roller chains (F) and a triple sprocket. The triple sprocket is driven directly from the conditioner cross shaft (G) by a roller chain (H). All the drive chains have separate adjustable idler sprockets.

The left-hand cross shaft (I) drives the left-hand draper canvas and cutterbar. The left-hand canvas is driven by a V-belt (J). The cutterbar drive case (K) is driven by a V-belt (L) with an adjustable idler pulley.

049;E17039 E05;1015 2A 200882



*Description*

### LUBRICATE PLATFORM PROPERLY

**IMPORTANT:** Correct selection and proper use of lubricating oils and grease is very important in keeping upkeep costs low, while providing long platform life with satisfactory service.

Use only lubricants specified in this section. Lubricate at the intervals listed and according to the following instruction.

0A9: E05;1020 ZA 300682

### CHOOSING A GREASE

John Deere Multipurpose Grease is recommended in all grease fittings at hourly intervals indicated. If other greases are used, use:

- SAE Multipurpose Grease
- SAE Multipurpose Grease containing 3 to 5 percent molybdenum disulfide.

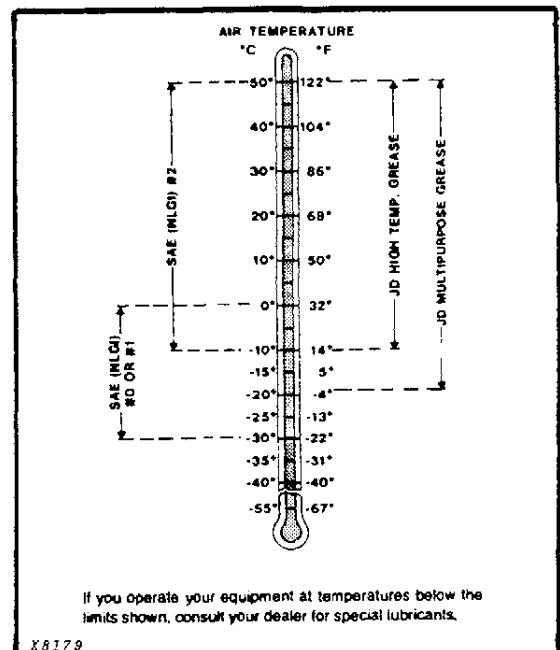

0A9;X8179 E05;1424;M C 150582

### KNIFE DRIVE CASE

Fill the drive case to 64 to 89 mm (2-1/2 to 3-1/2 inches) below fill plug (A) with SAE 85-140 API-GL5 Gear Lubricant.

**IMPORTANT: Overfilling can cause leakage, overheating and contribute to internal damage. Fill no higher than 64 to 89 mm (2-1/2 to 3-1/2 inches) below fill plug.**

If other oils are used, they must meet performance requirements of:

- API Service Classification GL-5
- Military Specification MIL-L-2105C

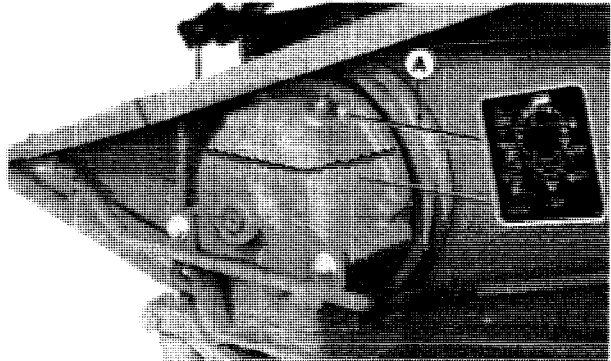

0A9;E21079 E05;1020 ZD 150682

### GEAR CASE

Fill gear case to 41 mm (1-5/8 in.) from bottom with SAE 85-140 API-GL5 Gear Lubricant.

**IMPORTANT: Overfilling can cause leakage, overheating and contribute to internal damage. Fill no higher than 41 mm (1-5/8 in.) from bottom of gear case.**

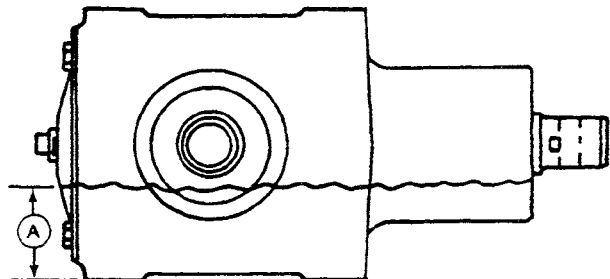

0A9;E16951 E05;1020 ZE 300682

### USE APPROVED ALTERNATE LUBRICANTS

Conditions in certain geographical areas outside the United States and Canada may require different lubricant recommendations than those printed in the technical manual.

0A9; E05;1020 ZF 300682